

PAW-TD20/30C1E5-UK PAW-TD20/30C1E5-UK-1



Installation Manual

Contents

	Page no.
1. General information	2
2. Preparation of installation area	4
3. Pipe connections	4
4. Commissioning and filling up	5
5. Draining and Flushing	5
6. Electrical installation	5
7. Safety and Servicing	9
8. Fault finding	10
9. Technical and Performance specs... ..	11
10. Warranty	12
11. Log book	13

This cylinder is manufactured and approved in accordance with EN 12897 : 2006

Thank-you for purchasing the PAW unvented hot water cylinder.

The PAW is an unvented hot water cylinder in capacities 200 and 300 litres. Its energy efficiency as defined by standing heat losses is the best in its class and will save the householder significant energy costs over the lifetime of the cylinder.

This manual gives detailed advice for installation and should be read carefully prior to fitting any unvented unit. PAW cylinders are not suitable for gravity fed primary systems. In known hard water regions, precautions should be taken to prevent limescale formation in hot water cylinders, in accordance with Building Regulation Part L, Domestic Heating Compliance Guide.

This cylinder must be installed by a competent person and be installed in compliance with the Installation and Maintenance Instructions, all current legislation, codes of practice and regulations governing the installation of unvented hot water cylinders in force at the date of installation.

**PLEASE READ THIS MANUAL BEFORE INSTALLATION AND LEAVE WITH THE UNIT.
THE MANUAL AND ATTACHED LOGBOOK SERVE AS THE CYLINDER GUARANTEE.**

1. General information

1.1 Health and Safety regulations

Handling Operations Regulations 1992 defines manual handling as: “any transporting or supporting of a load (including the lifting, putting down, pushing, pulling, carrying or moving thereof) by hand or bodily force” The Regulations set no specific requirements such as weight limits. However common sense still has to be used based on an ergonomic approach for each individual.

The PAW cylinder should be transported and stored in a vertical position.

1.2 Siting the PAW cylinder

There are few restrictions on the siting of the PAW cylinder, however it should not be sited anywhere open to frost attack. The unit should be placed on a stable flat surface capable of withstanding the weight of the cylinder when full (see technical data on page 11) and access must be allowed for maintenance purposes. Provision should also be allowed for the routing of the discharge pipe away from the cylinder to an outside point according to building regulation G3. (See page 10).

1.3 Component Check list

Components supplied with the unit in a separate accessory kit for site fitting:

- Multibloc valve, includes pressure reducing valve, line strainer, balanced cold water take off, (for shower or bidet only) check and expansion valve.
- Tundish
- 3/4" x 22mm Elbow / Drain Cock
- Motorised valve
- Expansion vessel.

1.4 Components factory fitted

- Immersion heater with thermostat and thermal cut-out
- Additional cylinder thermostats with thermal cut-out (for indirect heat source)
- Temperature and pressure relief valve.

1.5 Documentation supplied

- Installation manual & log book

1.6 Supply requirements

An uninterrupted 22mm cold water mains supply is recommended, however if only a 15mm supply is available, this may be used provided there is sufficient flow rate available, a minimum standing pressure of 2.5 bar and a flow rate of 20 litres per minute with a 1bar dynamic pressure is recommended. The cylinder will operate at lower pressures and flow rates however the performance will be compromised. The PAW unvented unit is designed for use with supply pressure up to 10 bar. For pressures over 10 bar an additional pressure reducing valve must be fitted in the supply pipe to the unit.

1.7 Expansion vessels

The vessel accommodates expanded water when the cylinder is heated and prevents the cylinder reaching its maximum working pressure.

1.8 Compatible fittings and components

All thermostatically controlled heat pumps and boilers are compatible with indirect PAW cylinders.

Heat sources to unvented hot water cylinders must be controlled by a thermal cut-out as well as a thermostat. The PAW cylinders is supplied with sensor bosses and pockets to house temperature sensors linked to the heat pump or boiler.

1.9 Non-compatible products.

Solid fuel boilers, wood burning stoves and other non-thermostatically controlled heat sources must not be used with unvented cylinders.

General Layout

PAW-TD..C1E5-UK

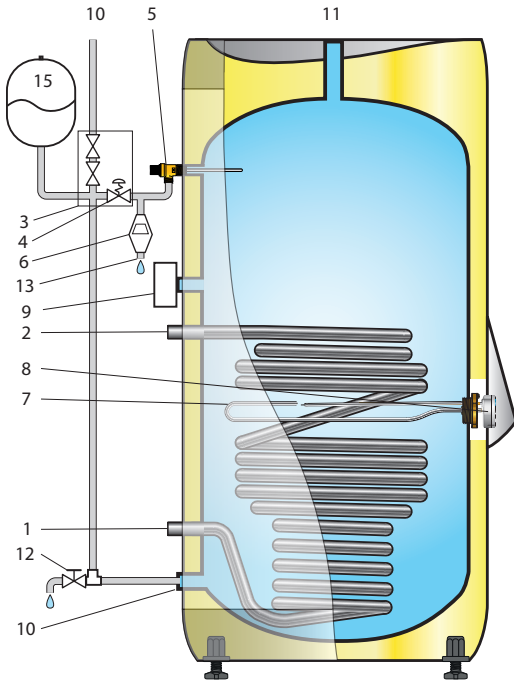

PAW-TD..C1E5-UK-1

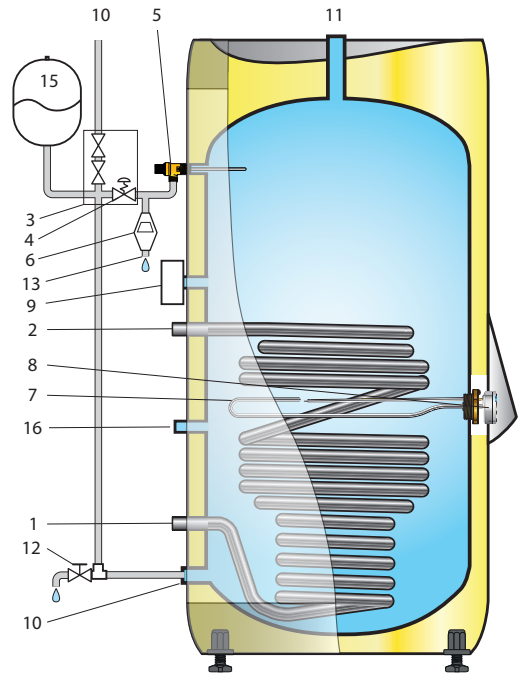

No.	Key	P/N
1	Return HP 3/4" BSP (Flow Boiler 3/4" BSP)	
2	Flow HP 3/4" BSP (Return Boiler 3/4" BSP)	
3	Pressure Reducing Valve	
4	Multibloc (2.1 bar) includes Item 4	
5	Expansion Relief Valve (8 bar)	
6	Temperature and Pressure Relief Valve	92020
7	Tundish	
8	Immersion Heater	71234
9	Immersion heater Control Thermostat	80314
10	Cylinder Thermostat w/ safety cut-out	80345
11	Cold Water Inlet 3/4" BSP / Ø22	
12	Hot Water Outlet 3/4" BSP	
13	Elbow / Drain Cock	
14	Discharge Pipe (Not supplied)	
15	Motorised Valve (Not factory fitted)	
16	Expansion Vessel	

HW outlet 3/4" BSP female

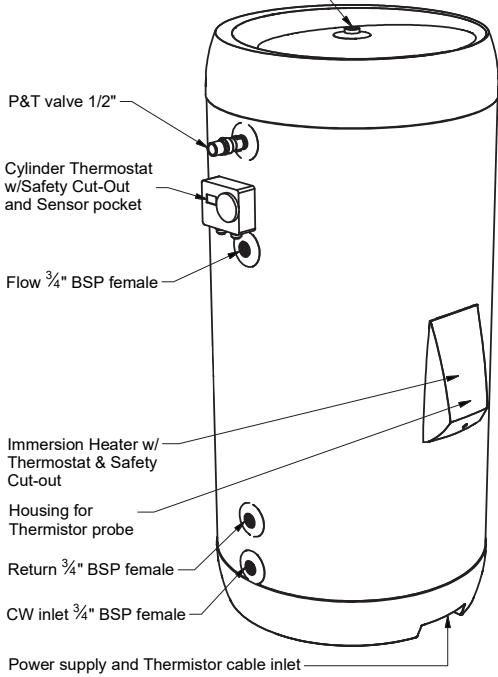

HW outlet 3/4" BSP female

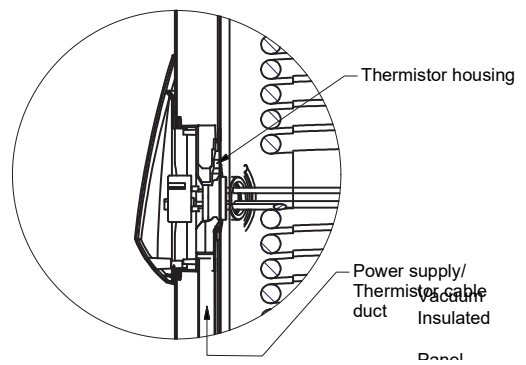
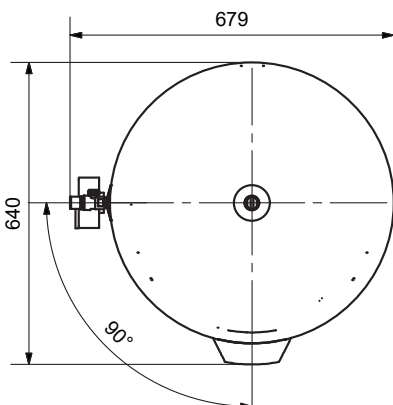
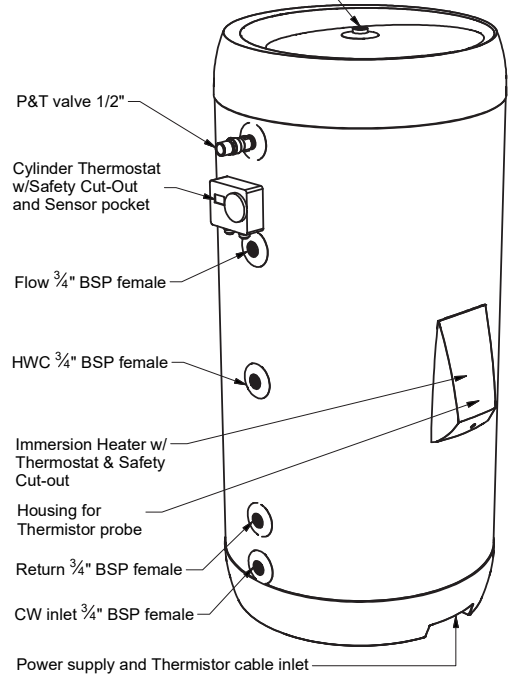

2. Preparation of installation area

2.1 Positioning the unit

The PAW cylinder should be fitted level on a hard surface with sufficient load strength to take the full weight of the cylinder (see technical data table page 11). The unit has 3 built-in adjustable feet to allow fine adjustment of the water heater.

There are no limitations regarding the fitting distance from walls etc., but it is strongly recommended to ensure easy access to all pipe fittings etc. The Temperature and Pressure relief valve and immersion heater are positioned at 90° apart. The PAW cylinder must be positioned to ensure that the tundish is visible and there is easy access to the thermostat and to remove the immersion heater if required.

2.2 Protection from frost

If the water heater is in danger of being exposed to frost while not operating under electric power, the unit must be drained to avoid damage. Make sure the electric power is turned off before draining, otherwise the heating elements can be damaged and the warranty is void. Draining instructions, see "Draining" on page 5.

3. Pipe Connections

3.1 Cold water supply

3.1.2 To obtain the best performance from your PAW unvented system it is advisable to feed the unit with an uninterrupted supply.

3.1.3 Before connecting to the multibloc, flush the cold supply pipework of all flux and debris.

3.1.4 Locate the cylinder in a suitable position to facilitate the installation of the cold water supply, discharge fittings and pipework. Also take into account access to the immersion heater.

3.1.5 Fit the combined male elbow drain cock to cold supply point (12) and make CW pipe in accordance to General Layout on page 3.

3.1.6 Fit the Multibloc(3) to the CW pipe.

3.1.7 Connect 15mm copper tube from the expansion relief valve (4) and also from the T & P valve (5) and join together in a Tee as shown on page 3.

3.1.8 Fit the tundish (6) to the bottom connection of this tee.

3.1.9 Connect the cold supply to the multibloc(3).

3.1.10 Fit the expansion vessel to the wall close to the water heater using the enclosed mounting bracket. Connect the expansion vessel to the multibloc, as shown on page 3.

3.2 Hot water supply

Connect the hot water supply pipe to the outlet (11). Ensure connection is water tight.

3.3 Balanced cold water supply (optional).

If no balanced cold supply is required, tighten the supplied blanking cap. If a balanced mains pressure cold water supply is required to a shower or bidet (over rim type only, ascending spray type requires type AA,AB or AD air gap), remove blanking cap and connect to the shower or bidet cold supply on the multibloc valve (3).

(Major shower manufacturers advise fitting a mini expansion vessel in the balanced cold supply pipework to accommodate thermal expansion and prevent tightening of shower controls) Using the balanced cold connection to feed bath taps can reduce the flow available to the unvented cylinder.

3.4 Secondary return (optional)

Connect secondary return if required to connection 16 (page 3).

3.5 Discharge pipe

Connect the tundish outlet to the discharge pipe. Install the Tundish in a vertical position within a maximum of 600 mm from the Temperature and Pressure Relief Valve drain connection and away from electrical components. Ensure the expansion relief pipework discharges through the tundish. Tundish pipework must be 22 mm with a minimum vertical length of 300 mm below tundish. Maximum permitted length of 22 mm pipework is 9 m. Each bend or elbow is equivalent to 0.8 m of pipework. All pipework must have continuous fall and discharge in a safe, visible position. If any doubt, refer to Building Regulation G3.

Discharge pipe must be dedicated to the cylinder and must not be used for any other purpose.

3.6 Primary Flow and Return and Motorised valve

3.6.1 The heat pump/boiler primary flow and return connections should be made connections 1 & 2. The motorized valve can be connected to either the primary flow or return pipe. The primary flow and return fittings are 3/4" BSP female. The direction of primary flow in the coil is bottom to top. The maximum operating temperature of the primary flow would typically be 82°C.

3.6.2 For electrical connection of the motorised valve and immersion heater, please read Electrical Installation Instructions. (Page 5).

4. Commissioning and filling up

4.1 Commissioning

4.1.1 Check all connections for tightness.

4.1.2 Open hot water tap furthest away from the PAW cylinder. Open the mains stop cock to fill the water heater. When water flows evenly from tap, allow to run for a few minutes to flush through any dirt, swarf or residue, then close the tap. Open successive hot taps to purge any remaining air.

4.1.3 Check all water connections for leaks and rectify if necessary.

Manually operate Expansion relief valve 4 (see page 3) to ensure free water flow through discharge pipe by turning knob counter-clockwise. To close continue to turn counter-clockwise until the valve shuts.

Manually operate Temperature and Pressure Relief Valve 5 (see page 3) to ensure free water flow through discharge pipe.

5. Draining & flushing out the system

5.1 Draining

Switch off the electrical power (Important to avoid damage to element). Isolate heat pump/boiler from cylinder. Turn off the cold water supply valve. Open hot water tap. Open drain 12 (see page 3) at base of cylinder.

The unit will drain. Draining process may be speeded up by opening the temperature and pressure relief valve. An internal ø18 mm hose can be applied to lead the water to a gully, sink or similar.

5.2 System flushing

This will not be necessary under normal circumstances as the line strainer will prevent ingress of foreign materials, however if flushing is required, run at least 50 litres of water from the cylinder at the highest possible flow rate. Close the taps and follow draining procedure (above).

6. Electrical installation - all wiring must conform to current IEE regulations

6.1 Immersion heater Thermostat

The immersion heater is designed as an auxiliary heater as an emergency back-up. Power to immersion heaters should not be switched on until the unit is filled with water. All units are fitted with one 1.5 kW @230V immersion heater which is located behind the electrical box. Alternative thermostats should not be used, regulations require immersion heaters on unvented cylinders to be connected with a thermal cut-out. Follow the wiring instructions below connecting the live, neutral and earth as indicated. The unit must be permanently connected to the electrical supply and each circuit must be protected by a suitable fuse and double pole isolating switch, compliancy to IEE regulations.

The immersion heater has a working thermostat adjustable between 18°C - 70°C (+/- 5°C). A safety cut-out is also incorporated within the thermostat and will operate at 87°C (± 5°C). Should this happen, check reasons for thermal cut-out button being released and when satisfied press the reset button.

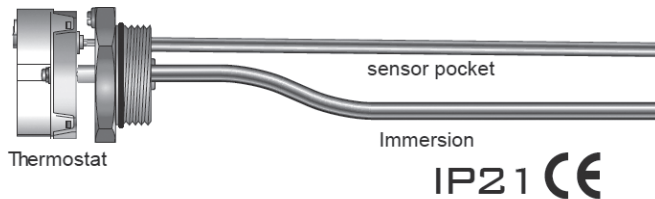
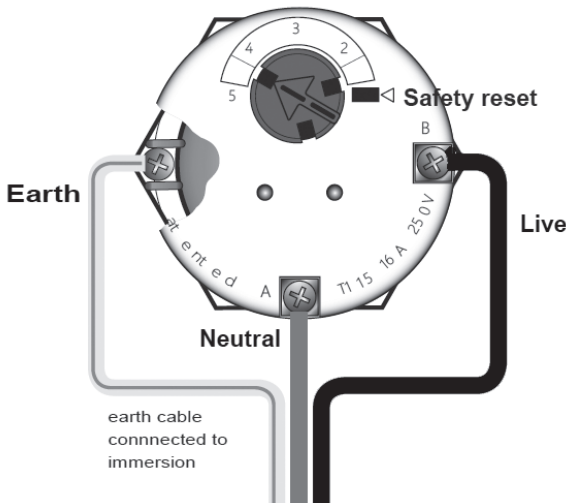

OSO Hotwater AS can not be held responsible if alternative wiring plans are used.

Important: Before resetting the safety cut-out or altering the thermostat setting isolate electrical supply to the unit before removal of the lid. Ensure the lid to the electrical box is replaced.

6.2 Motorised valve

To comply with regulations governing the installation of indirect unvented cylinders, a motorised valve must be fitted in the primary pipework. The motorised valve will act as a positive energy cut-out should the additional cylinder thermal cut-out operate. The motorised valve will also control the temperature of the domestic stored water via the additional cylinder thermostat. The unit can be installed on an "S" or "Y" plan system. Please follow the wiring instructions carefully.

6.4 Digital Dual Cylinder Thermostat

The Digital Dual Cylinder thermostat has real safety and energy saving benefits and provides accurate temperature control. It also features a clear and informative LCD display. Leave the cylinder thermostat set at 60°C in line with current government guidelines. Lowering the temperature will substantially reduce the amount of usable hot water available on a daily basis and could result in bacterial growth unless the legionella facility is activated (THIS FUNCTION IS ACTIVATED AS STANDARD see label on side of thermostat, for commissioning purposes please disable this function selecting OF in display see 6.4.1 below).

The legionella mode gives a weekly automatic one hour "boost" to above 60°C which kills any legionella bacteria. This function is adjustable allowing the duration of the legionella override to be adjusted from 1 to 7 days or completely disabled to operate as a conventional Dual Cylinder Thermostat. The LCD display shows the current water temperature and the user defined water temperature, while the red LED indicates that the unit is calling for heat. The sensitive electronic sensors operate at a far greater accuracy than conventional thermostats. The dial makes it easy to set the required controller temperature (between 25°C and 65°C). The second (limit) safety thermostat is pre-set to 80°C with a concealed manual reset, to comply with building regulations. Should the safety cut out be brought into operation, the motorised valve will operate and close down the primary flow to the cylinder. To reset the safety cut-out and the motorised valve the reset button must be pressed in.

Wiring Diagram

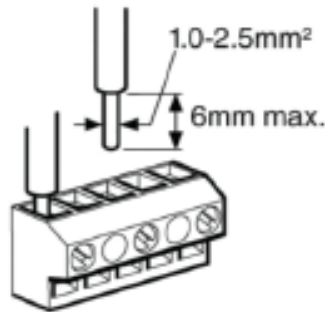

Also see S-plan and Y-plan wiring page 7 and 8.

This product requires a fused permanent Live and Neutral supply.

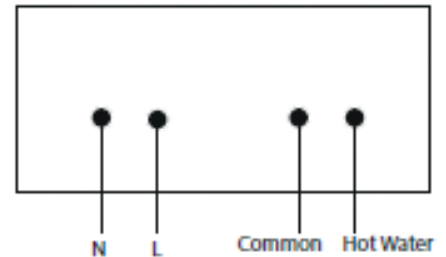

6.4.1 Adjusting the 1 Hour Boost

The thermostat has user defined settings where the duration of the legionella Override/Boost can be adjusted from 1 to 7 days or completely disabled to operate as a conventional dual cylinder thermostat.

1. To disable or adjust the legionella override/ boost turn the unit off by pressing and holding down the HOLIDAY button until an audible click is heard.
2. Release the button and after approx. 10 seconds press and hold the holiday button again until an audible click is heard and the LCD display flashes
3. Release the button and use the HOLIDAY button to choose between disabling the override/Boost (OF in display) or setting delay between boost/override from 1 - 7 days (1-7 in display)
4. Once selected release the button and the unit will return to the user set position within 5 seconds

6.4.1 Holiday Mode

This is the black button located under the display. Press and hold the holiday switch for a minimum of 10 seconds until you hear an audible click, and this switches the digital Dual Cylinder Thermostat off completely so there is no water heating and no weekly "boost" heating.

When in Holiday mode, the display is off. This feature should only be used when the property is vacant for extended periods and there is no requirement for water heating or for the weekly "boost". Pressing and holding the holiday switch again (for a minimum of 10 seconds until you hear an audible click) will restart the Electronic Dual Cylinder Thermostat, the display will show the cylinder temperature and the weekly "boost" will immediately start, and recur every 7 days at the same time.

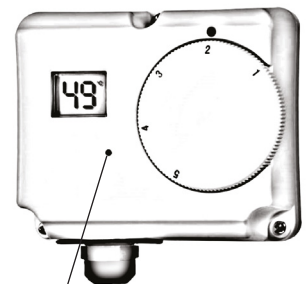

Holiday mode

OSO Hotwater AS can not be responsible if alternative wiring plans are used. Important: Before resetting the safety cut-out or altering the thermostat setting isolate electrical supply to the unit before removal of the lid.

S-plan Wiring

PAW cylinders can be fitted with all types of boilers and heat pumps operating using room and cylinder thermostats.

Please follow upper diagram: 'Wiring for Standard Heat Pump'.

Thermistor controlled Heat Pumps/Boilers

Many popular Heat Pumps now use a thermistor principle. A thermistor temperature sensor is supplied with the Heat Pump to attach to the cylinder.

Temperature information is relayed back to the Heat Pump control system.

A Pocket is provided (see below to secure the sensor on the PAW cylinder. The

probe is run through a channel from base of cylinder to the immersion housing and housed there in a pocket. The thermistor cable should be secured using the supplied clamps in the bottom opening of the channel. A motorised valve must be used in accordance with Building Regulation G3. This is wired from the additional cylinder thermostat, wired as high limit stat. Please follow lower diagram: 'Wiring for Thermistor Controlled Heat Pump'

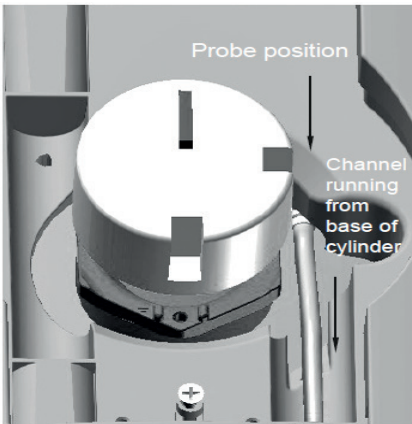

Channel running from base of cylinder

Using Additional Cylinder Thermostat as high limit stat:

- coil the grey temperature probe wire inside additional cylinder thermostat box and insert black probe into thermostat pocket of cylinder then turn dial on front to number 5

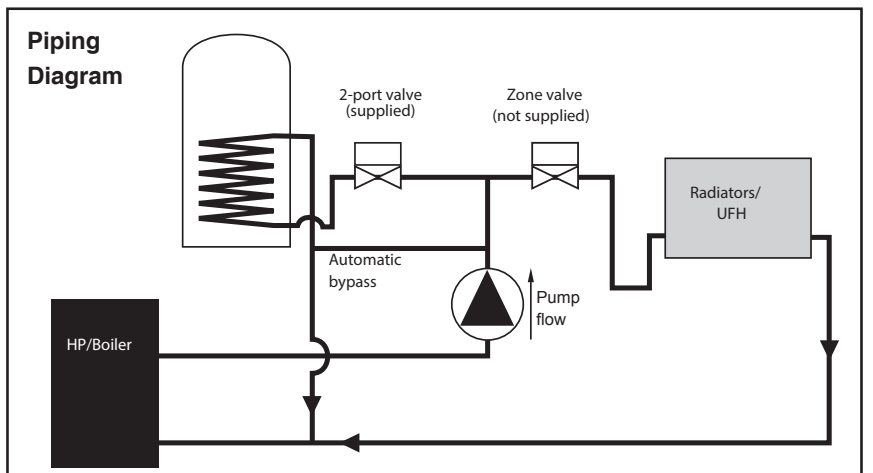
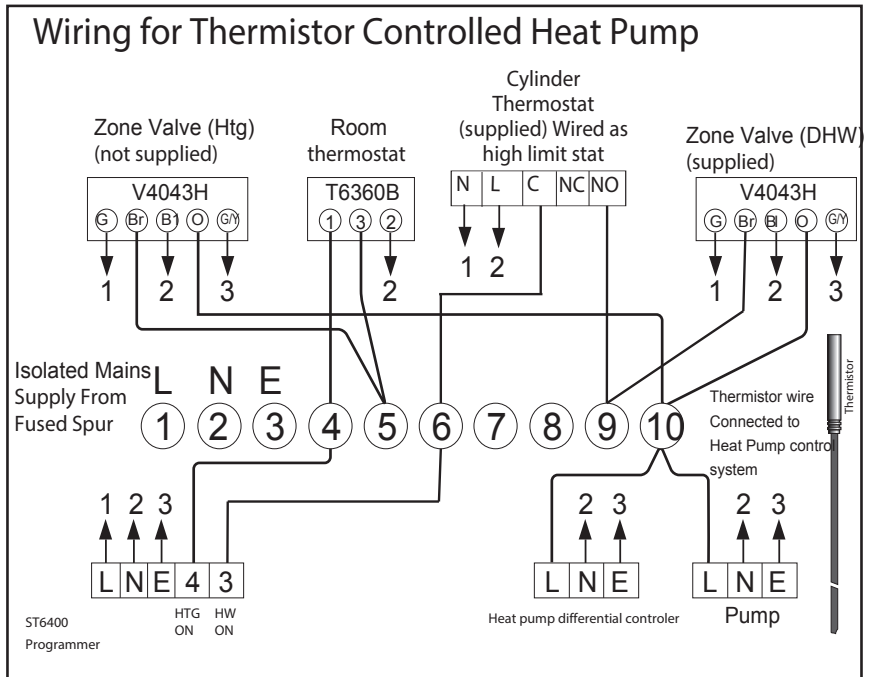
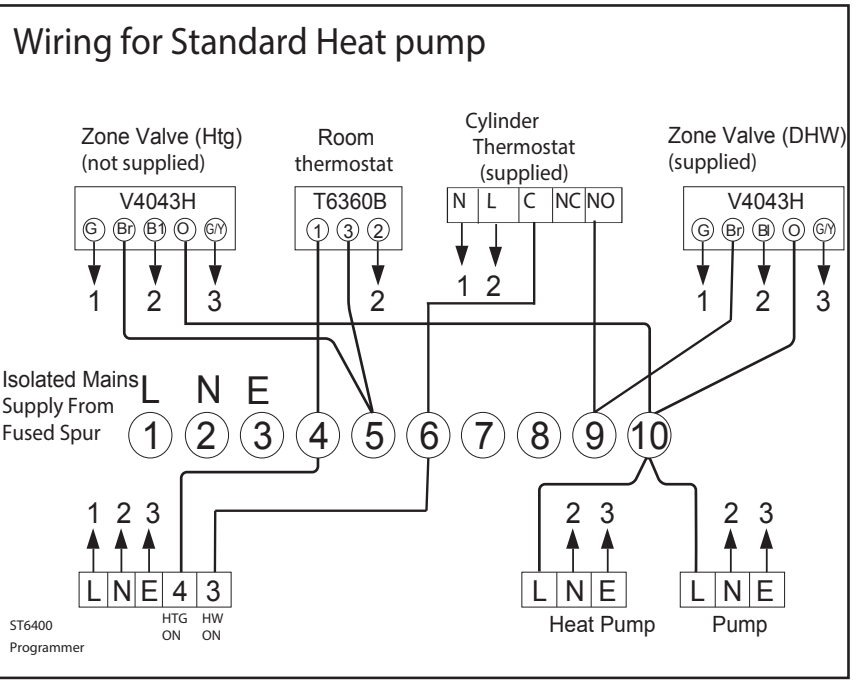

Y-plan Wiring

PAW cylinders can be fitted with all types of boilers and heat pumps operating using room and cylinder thermostats. Please follow upper diagram: 'Wiring for Standard Heat Pump'.

Thermistor controlled Heat Pumps/Boilers

Many popular Heat pumps now use a thermistor principle. A thermistor temperature sensor is supplied with the Heat Pump to attach to the cylinder. Temperature information is relayed back to the Heat Pump control system.

A Pocket is provided (see below to secure the sensor on the PAW cylinder. The probe is run through a channel from base of cylinder to the immersion housing and housed there in a pocket. The thermistor cable should be secured using the supplied clamps in the bottom opening of the channel. A motorised valve must be used in accordance with Building Regulation G3. This is wired from the supplied cylinder thermostat, wired as high limit stat. Please follow lower diagram: 'Wiring for Thermistor Controlled Heat Pump'.

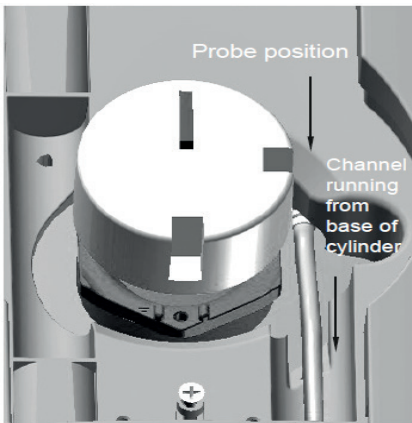

Channel running from base of cylinder

Using Additional Cylinder Thermostat as high limit stat only:

- coil the grey temperature probe wire inside additional cylinder thermostat box and insert black probe into thermostat pocket of cylinder then turn dial on front to number 5

Wiring for Standard Heat pump

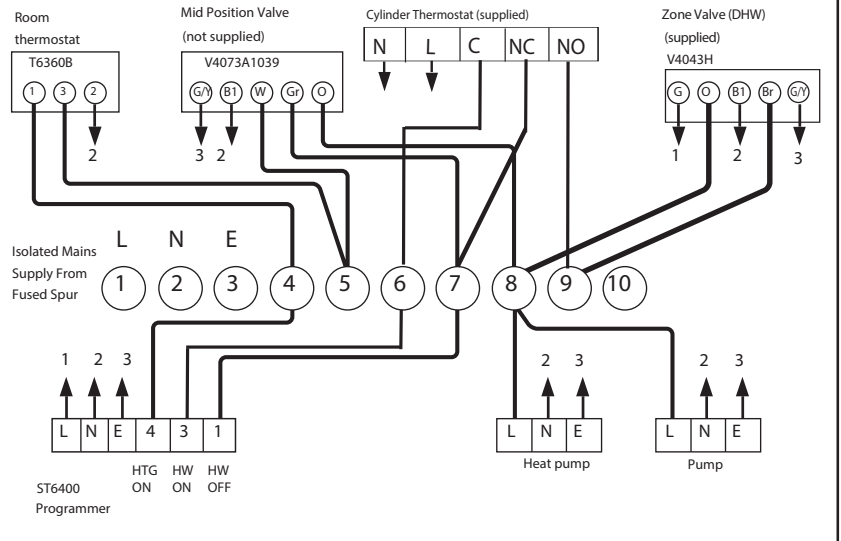

Wiring for Thermistor Controlled Heat Pump

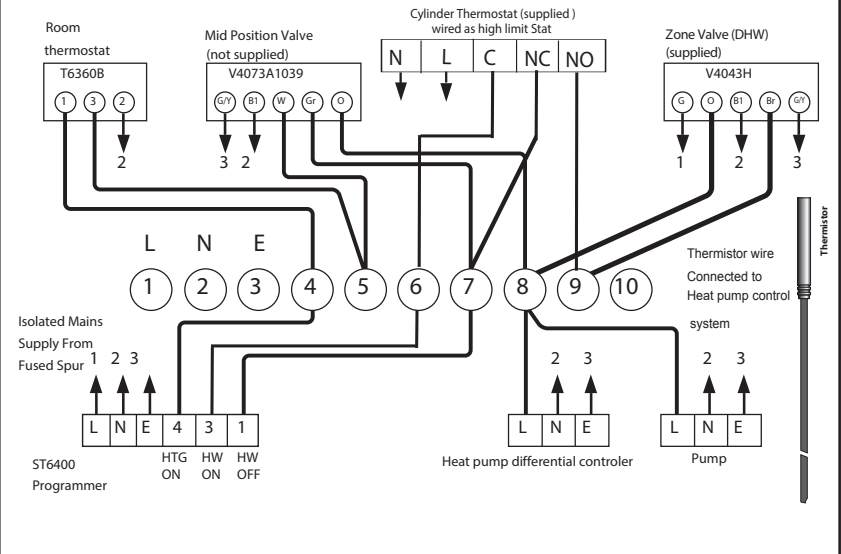

Piping Diagram

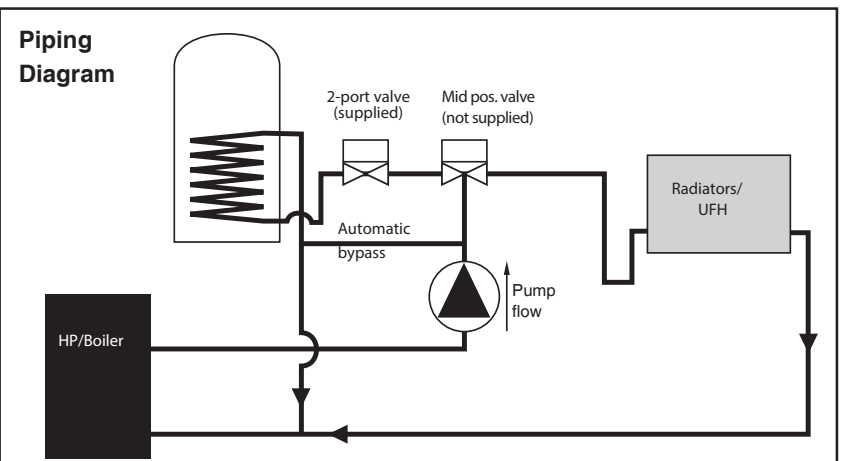

7. Safety and servicing

Maintenance must be carried out by a competent person.

7.1 Safety Cut-out

The safety cut-out operates if:

1. Wiring is incorrect.
2. The immersion heater thermostat or additional cylinder thermostat fails.
3. Thermostat is set too high.
4. Remember before resetting the safety cut-out or altering the thermostat setting, isolate electrical supply to the unit prior to removal of the electrical box lid.
5. Reduce thermostat setting and press the reset button. After adjustments are completed, ensure the lid to the electrical box is replaced.
6. If still out of operation, contact installer.

7.2 Intermittent or slow discharge from tundish

1. Turn off the electrical supply to the immersion heaters.
2. Turn off cold water supply valve.
3. Open a hot tap.
4. Turn the knob on the Temperature and Pressure Relief Valve (5) to the left and hold in this position for thirty seconds.
5. Attach a foot pump with a schraeder (car type) valve to the expansion vessel.
6. Pump up to 3 bar
7. Open cold water supply valve.
8. When water flows through open tap, close tap
9. Turn on electrical supply to the immersion heaters.

7.3 Continuous very hot water discharge from tundish

This indicates a malfunction of a thermal cut-out, operating thermostat or the combined temperature and pressure relief valve. Turn off the electrical supply to the immersion heater and also isolate the indirect unit from the heat pump/boiler. Contact the installer or competent engineer.

7.4 Expansion vessel maintenance

The expansion vessels do not require annual maintenance and should not be tampered with unless an intermittent or slow discharge from the tundish occurs when water is being heated. In this situation, maintenance must be carried out by competent person and the precharge pressure must be restored to the original value. An annual visual inspection is recommended. Important: To check the precharge the expansion vessel must be completely empty of water. If the precharge pressure is different from the value shown on the label it must be restored to the original value.

Do not remove expansion vessel without depressurising the cylinder and draining 10 litres of water from the drain valve at the base of the cylinder.

7.5 Guarantee

Cylinder should be serviced annually and the log book should be updated in order to validate guarantee. The log book and service records act as guarantee document. For terms of guarantee please see the log book on page 15.

7.6 Servicing Procedure:

7.6.1 Expansion relief valve

Ensure that expansion relief valve works by manually opening to discharge water to tundish.

7.6.2 Pressure reducing valve

Isolate the cold water supply and open a ground floor cold tap. Unscrew the pressure reducing cartridge. Clean the filter mesh and the cartridge under running water. Replace cartridge ensuring that strainer is correctly located and reassemble the unit.

7.6.3 Expansion relief cartridge

Isolate the cold supply and open a ground floor cold tap. unscrew blue expansion relief headwork from valve body. Clean valve seat face and seating - do not scratch or damage either seat face or seating. Refit in reverse order. Do not overtighten.

7.6.4 Temperature and Pressure relief valve

Ensure that Temperature & Pressure Relief valve works by manually opening to discharge water to tundish.

7.6.5 Internal inspection

The immersion heater can be removed to provide visual inspection access to the cylinder.

8. Fault Finding Guide

FAULT	POSSIBLE CAUSE	SOLUTION
No water flow from hot taps.	1. Mains supply off. 2. Strainer blocked.	1. Check and open stopcock. 2. Turn off water supply. Remove strainer and clean (see Servicing Procedure page 10).
Water from hot taps is cold.	1. Immersion heaters not switched on. 2. Immersion heater thermal cut-out has operated 3. Programmer set to central heating or not switched on. 4. Heat Pump/Boiler not working. 5. Cylinder thermal cut-out has operated (indirect units only). 6. Motorised valve not operating correctly.	1. Check and switch on. 2. Check and reset button (see thermostat diagram page 8 and safety cut-out on page 5 of installation manual). 3. Check and set to hot water. 4. Check Heat Pump/Boiler operation. If fault suspected consult installer or Heat Pump/Boiler manufacturer. 5. As at No. 2. 6. Check wiring and/or plumbing connections to motorised valve (see pages 6 - 9 of the installation manual).
Intermittent water discharge.	1. Reduced expansion vessel charge.	1. Follow instruction page 9: "Intermittent or slow water discharge from tundish".
Continous water discharge.	1. Thermal control failure (Note: Water will be hot). 2. Cold water inlet Pressure Reducing Valve not working. 3. Temperature and pressure relief valve faulty. 4. Expansion relief valve not working properly.	1. Switch off power to immersion heater(s) and heat pump/boiler supply to the unit. When discharge has stopped, check thermal controls, replace if faulty. Contact a competent person. 2. Check pressure from valve, if greater than 3 bar replace (see page 9 of installation manual). 3. Drain 10 litres from cylinder and replace valve. 4. Check and replace if faulty (see page 6 of installation manual).
Important - note: Disconnect electrical supply before removing any electrical equipment covers.		

Alternative Discharge

Discharge pipes should be in metal and dedicated to the unvented cylinder. The pipe should have a continuous fall and should terminate in a safe and visible place.

Downward discharges at low level, i.e. up to 100 mm above external surfaces such as car parks, hard standings, grassed areas etc. are acceptable providing that where children may play or otherwise come into contact with discharges, a wire cage or similar guard is positioned to prevent contact, whilst maintaining visibility.

Discharge at high level, i.e. into a metal hopper and metal down pipe with the end of the discharge pipe clearly visible (tundish visible or not) or onto a roof capable of withstanding high temperature discharges of water and 3 m from any plastics guttering system that would collect such discharges (tundish visible).

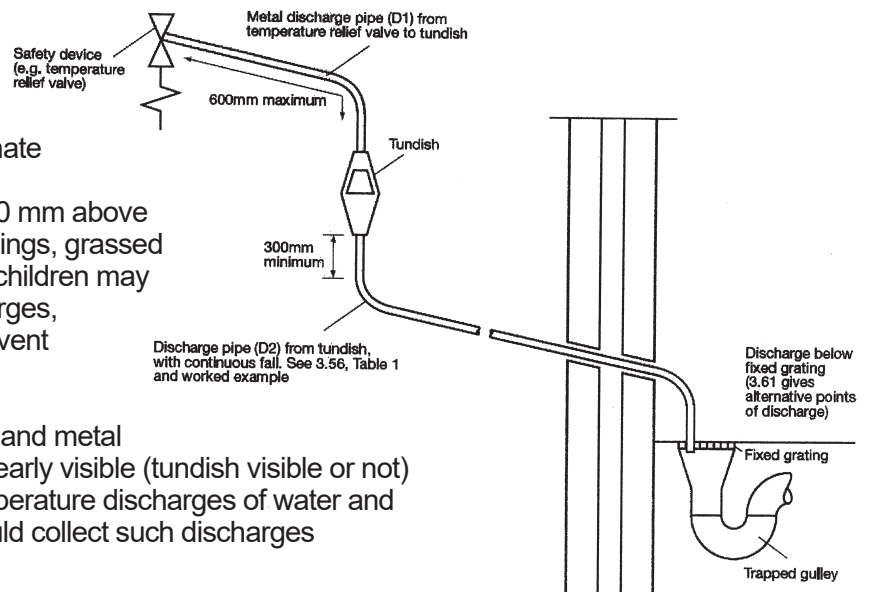

Where a single pipe serves a number of discharges, such as in blocks of flats, the number served should be limited to not more than 6 systems so that any installation discharging can be traced reasonably easily. The single common discharge pipe should be at least one pipe size larger than the largest individual discharge pipe to be connected. For further information contact your Building Control Office.

TABLE D

Valve outlet size	Minimum size of discharge pipe D1*	Minimum size of discharge pipe D2* from tundish	Maximum resistance allowed, expressed as a length of straight pipe (i.e. no elbows or bends)	Resistance created by each elbow or bend
G1/2	15 mm	22 mm	up to 9 m	0.8 m
		28 mm	up to 18 m	1.0 m
		35 mm	up to 27 m	1.4 m
G3/4	22 mm	28 mm	up to 9 m	1.0 m
		35 mm	up to 18 m	1.4 m
		42 mm	up to 27 m	1.7 m
G1	28 mm	35 mm	up to 9 m	1.4 m
		42 mm	up to 18 m	1.7 m
		54 mm	up to 27 m	2.3 m

Technical data

Description	Unit	PAW-TD20C1E5-UK	PAW-TD30C1E5-UK	PAW-TD20C1E5-UK-1	PAW-TD30C1E5-UK-1
Actual capacity of the water tank at 20°C	L.	192	284	192	284
Outer diameter of the tank	mm	595	595	595	595
Height of the appliance	mm	1270	1750	1270	1750
Gross weight of the appliance	kg	50	61	50	61
Net weight of appliance once filled with sanitary water	kg	241	341	241	341
Material of element	-	incoloy 825	incoloy 825	incoloy 825	incoloy 825
Thermal insulation material	-	PUR+VIP	PUR+VIP	PUR+VIP	PUR+VIP
Thermal insulation of the tank, average thickness	mm	50	50	50	50
IP classification	-	21	21	21	21
Standby heat losses / 24 hour	kWh/24h	1.01	1.15	1.03	1.18
Standby heat losses	Watts	42	48	43	49
V40 Hotwater volume	L.	315	465	315	465
Primary flowrate for Reheat time & Primary heating power	l/h	900	900	900	900
Heating up time heating coil	min	18.5	26.08	18.5	26.08
Primary Heating power heating coil	kW	35	32	35	32
Primary Heating coil pressure drop	mbar	120	120	120	120
Heat up time immersion heater	min	255	464	255	464
ErP class	-	A	A	A	A
Pressure information					
Design pressure of cylinder (rated pressure)	MPa/Bar	1 / 10	1 / 10	1 / 10	1 / 10
Design pressure of heating coil	MPa/Bar	1 / 10	1 / 10	1 / 10	1 / 10
Operating pressure of cylinder	MPa/Bar	0.3 / 3	0.3 / 3	0.3 / 3	0.3 / 3
Operating pressure of heating coil	MPa/Bar	0.25 / 2.5	0.25 / 2.5	0.25 / 2.5	0.25 / 2.5
Max. operating temperature of cylinder	°C	70	70	70	70
Max. operating temperature of heating coil	°C	99	99	99	99
Hydraulic connections					
Secondary return	Inch	3/4"	3/4"	3/4"	3/4"
Primary Heating coil Flow	Inch	3/4"	3/4"	3/4"	3/4"
Primary Heating coil Return	Inch	3/4"	3/4"	3/4"	3/4"
Cold water	Inch	3/4"	3/4"	3/4"	3/4"
Hot water	Inch	3/4"	3/4"	3/4"	3/4"
Immersion heater	Inch	5/4"	5/4"	5/4"	5/4"
T&P valve (factory fitted)	Inch	1/2"	1/2"	1/2"	1/2"
Temperature sensor sleeve diameter	mm	8	8	8	8
Electrical characteristics					
Supply voltage and frequency	WHz	220-240 VAC	220-240 VAC	220-240 VAC	220-240 VAC
Power of the electrical resistance	kW	1.5kW@230V	1.5kW@230V	1.5kW@230V	1.5kW@230V
Electrical installation	-	IEEE regs	IEEE regs	IEEE regs	IEEE regs
Thermostat type - immersion/cylinder	-	Probe/Probe	Probe/Probe	Probe/Probe	Probe/Probe
Immersion Heater - Phase	Phase	single	single	single	single
Immersion thermostat - temp range	°C	8-70	18-70	8-70	18-70
Immersion thermostat - set temp	°C	60	60	60	60
Safety					
Safety valve opening pressure +/- 5%	MPa/Bar	0.8 / 8	0.8 / 8	0.8 / 8	0.8 / 8
T&P valve opening pressure/Temp.	MPa(Bar) /°C	1/90 (10/90)	1/90 (10/90)	1/90 (10/90)	1/90 (10/90)
Safety thermostat cutout - immersion	°C	87	87	87	87
Safety thermostat cutout - cylinder	°C	80	80	80	80

Technical Data Sheet - Indirect storage tank - ErP data

Directive: 2010/30/EU Regulation: EU 812/2013		Directive: 2009/125/EU Regulation: EU 814/2013		
Water heater Efficiency according to standard: prEN50440 : 2015				
M.T. ITEM No.	MODEL/IDENTIFIER	Rating ErP	Heat loss - W	Storage vol.
80341850	PAW-TD 20 C1E5-UK - 1,5kW / 1x230V	A	43	192
	PAW-TD 20 C1E5-UK-1 - 1,5kW / 1x230V			
80341950	PAW-TD 30 C1E5-UK - 1,5kW / 1x230V	A	49	284
	PAW-TD 30 C1E5-UK-1 - 1,5kW / 1x230V			

This product is manufactured by OSO Hotwater AS, Industriveien 1, 3300 Hokksund, Norway.

Warranty

1. Scope

The Distributor warrants for 2 years from the date of purchase, that the Product will: i) conform to specification, ii) be free from defects in materials and workmanship, subject to conditions below.

The warranty only applies to Products purchased by a consumer, that has been installed for private use and that has been sold by the Distributor or a designated retailer where the Products have been originally sold by the Distributor.

The warranty does not apply to Products purchased by commercial entities or for Products that have been installed for commercial use. These shall be subject only to the mandatory provisions of the law. The conditions and limitations set out below shall apply.

2. Coverage

If a defect arises and a valid claim is received within the statutory warranty period, at its option and to the extent permitted by law, the Distributor shall either; i) repair the defect, or; ii) replace the product with a product that is identical or similar in function, or; iii) refund the purchase price.

Any exchanged Product or component will become the legal property of the Distributor. Any valid claim or service does not extend the original warranty. The replacement Product or part does not carry a new warranty.

3. Conditions

The warranty applies only if the conditions set out below are met in full:

- The Product has been installed by a professional installer, in accordance with the instructions in the installation manual and all relevant Codes of Practice and Regulations in force at the time of installation.
- The Product has not been modified in any way, tampered with or subjected to misuse and no factory fitted parts have been removed for unauthorized repair or replacement.
- The Product has only been connected to a domestic mains water supply in compliance with the European Drinking Water Directive EN 98/83 EC, or latest version. The water should not be aggressive, i.e. the water chemistry shall comply with the following:

• Chloride	< 250 mg / L
• Total Dissolved Solids (TDS)	< 500 mg / L
• Saturation Index (LSI) @ 80°C	< 0,8
• pH level	< 9,5 / > 6,0
- The immersion heater is not exposed to hardness levels exceeding 20°dH.
- Any disinfection has been carried out without affecting the Product in any way whatsoever. The Product shall be isolated from any system chlorination.
- Service and/or repair shall be done according to the installation manual and all relevant codes of practice. Any replacement parts used shall be original spare parts supplied by the Distributor.
- Any third-party costs associated with any claim has been authorized in advance by the Distributor in writing.
- The purchase invoice and/or installation and servicing invoice, a water sample as well as the defective product is made available to the Distributor upon request.

Failure to follow these instructions and conditions may result in product failure, and water escaping from the Product.

4. Limitations

The warranty does not cover:

- Any fault or costs arising from incorrect installation, incorrect application, lack of regular maintenance in accordance with the installation manual, neglect, accidental or malicious damage, misuse, any alteration, tampering or repair carried out by a non-professional, any fault arising from the tampering with or removal of any factory fitted safety components or measures.
- Any consequential damage or any indirect loss caused by any failure or malfunction of the Product whatsoever.
- Any pipework or any equipment connected to the Product.
- The effects of frost, lightning, voltage variation, lack of water, dry boiling, excess pressure or chlorination procedures.
- Damage caused during transportation. Buyer shall give the carrier notice of such damage.
- Costs arising if the Product is not immediately accessible for servicing.

These warranties do not affect the Buyer's statutory rights.

*The code of practice for the installation,
commissioning & servicing of mains pressure hot water storage*

Installation, Commissioning and Service Record Log Book

CUSTOMER DETAILS

NAME	_____
ADDRESS	_____
	TEL No. _____

IMPORTANT

1. Please, keep the Log Book in a safe place for future reference.
2. This Log Book is to be completed in full by the competent person(s) who commissioned the equipment and then handed to the customer. When this is done, the Log Book is a commissioning certificate that can be accepted as evidence of compliance with the appropriate Building Regulations.
3. Failure to install and commission this appliance to the manufacturer's instructions may invalidate the guarantee.

The above does not affect your statutory rights.

INSTALLER & COMMISSIONING ENGINEER DETAILS

INSTALLER DETAILS

COMPANY NAME	DATE
ADDRESS	_____

INSTALLER NAME	TEL No.
REGISTRATION DETAILS	_____
REGISTERED OPERATIVE ID CARD No. (IF APPLICABLE)	_____

COMMISSIONING ENGINEER (IF DIFFERENT)

NAME	DATE
ADDRESS	_____

TEL No.	_____
REGISTRATION DETAILS	_____
REGISTERED OPERATIVE ID CARD No. (IF APPLICABLE)	_____

IT IS THE RESPONSIBILITY OF THE INSTALLER TO COMPLETE THIS LOGBOOK AND PASS IT ON TO THE CUSTOMER. FAILURE TO DO SO MAY INVALIDATE THE CYLINDER GUARANTEE

APPLIANCE & TIME CONTROL DETAILS

MANUFACTURER	MODEL		
CAPACITY	litres	SERIAL No.	
TYPE	UNVENTED		
TIME CONTROL	PROGRAMMER <input type="checkbox"/>	or	TIME SWITCH <input type="checkbox"/>

COMMISSIONING PROCEDURE INFORMATION

BOILER PRIMARY SETTINGS (INDIRECT HEATING ONLY) ALL BOILERS

IS THE PRIMARY A SEALED OR OPEN VENTED SYSTEM?	SEALED <input type="checkbox"/>	OPEN <input type="checkbox"/>
WHAT IS THE INDIRECT HEAT SOURCE FLOW TEMPERATURE?	<input type="text"/>	°C

ALL MAINS PRESSURISED SYSTEMS

WHAT IS INCOMING STATIC COLD WATER PRESSURE AT THE INLET TO THE PRESSURE REDUCING VALVE?	<input type="text"/>	bar
HAS STRAINER (IF FITTED) BEEN CLEANED OF INSTALLATION DEBRIS?	YES <input type="checkbox"/>	NO <input type="checkbox"/>
HAS A WATER SCALE REDUCER BEEN FITTED?	YES <input type="checkbox"/>	NO <input type="checkbox"/>
WHAT TYPE OF SCALE REDUCER HAS BEEN FITTED?	<input type="text"/>	

UNVENTED SYSTEMS

ARE COMBINED TEMPERATURE AND PRESSURE RELIEF VALVE AND EXPANSION VALVE FITTED AND DISCHARGE TESTED?	YES <input type="checkbox"/>	NO <input type="checkbox"/>
IS PRIMARY ENERGY SOURCE CUT OUT FITTED (NORMALLY 2 PORT VALVE)?	YES <input type="checkbox"/>	NO <input type="checkbox"/>
WHAT IS THE PRESSURE REDUCING VALVE SETTING (IF FITTED)?	<input type="text"/>	bar
WHERE IS OPERATING PRESSURE REDUCING VALVE SITUATED?	<input type="text"/>	
HAS THE EXPANSION VESSEL OR INTERNAL AIR SPACE BEEN CHECKED?	YES <input type="checkbox"/>	NO <input type="checkbox"/>
WHAT IS THE HOT WATER TEMPERATURE AT THE NEAREST OUTLET?	<input type="text"/>	°C

ALL PRODUCTS

DOES THE HOT WATER SYSTEM COMPLY WITH THE APPROPRIATE BUILDING REGULATIONS?	YES <input type="checkbox"/>
HAS THE SYSTEM BEEN INSTALLED AND COMMISSIONED IN ACCORDANCE WITH THE MANUFACTURER'S INSTRUCTIONS?	YES <input type="checkbox"/>
HAVE YOU DEMONSTRATED THE OPERATION OF THE SYSTEM CONTROLS TO THE CUSTOMER?	YES <input type="checkbox"/>
HAVE YOU LEFT ALL THE MANUFACTURER'S LITERATURE WITH THE CUSTOMER?	YES <input type="checkbox"/>
COMPETENT PERSON'S SIGNATURE	CUSTOMER'S SIGNATURE
<i>(To confirm demonstrations of equipment and receipt of appliance instructions)</i>	

PLEASE FOLLOW THE INSTALLATION AND COMMISSIONING INSTRUCTIONS IN THE INSTALLATION MANUAL SUPPLIED WITH THE EQUIPMENT

SERVICE INTERVAL RECORD

It is recommended that your hot water system is serviced regularly and that your service engineer completes the appropriate Service Interval Record below.

SERVICE PROVIDER

Before completing the appropriate Service Interval Record below, please ensure you have carried out the service as described in the manufacturer's instructions and in compliance with all relevant codes of practice.

SERVICE 1	DATE:
ENGINEER NAME	
COMPANY NAME	
TEL No.	
COMMENTS	
SIGNATURE	

SERVICE 2	DATE:
ENGINEER NAME	
COMPANY NAME	
TEL No.	
COMMENTS	
SIGNATURE	

SERVICE 3	DATE:
ENGINEER NAME	
COMPANY NAME	
TEL No.	
COMMENTS	
SIGNATURE	

SERVICE 4	DATE:
ENGINEER NAME	
COMPANY NAME	
TEL No.	
COMMENTS	
SIGNATURE	

SERVICE 5	DATE:
ENGINEER NAME	
COMPANY NAME	
TEL No.	
COMMENTS	
SIGNATURE	

SERVICE 6	DATE:
ENGINEER NAME	
COMPANY NAME	
TEL No.	
COMMENTS	
SIGNATURE	

SERVICE 7	DATE:
ENGINEER NAME	
COMPANY NAME	
TEL No.	
COMMENTS	
SIGNATURE	

SERVICE 8	DATE:
ENGINEER NAME	
COMPANY NAME	
TEL No.	
COMMENTS	
SIGNATURE	

SERVICE 9	DATE:
ENGINEER NAME	
COMPANY NAME	
TEL No.	
COMMENTS	
SIGNATURE	

SERVICE 10	DATE:
ENGINEER NAME	
COMPANY NAME	
TEL No.	
COMMENTS	
SIGNATURE	

When all the above services have been completed, please contact your Service Engineer for an additional service interval record sheet.

